



VDW AUTOMATIC HANDWASH DISPENSER

COMPONENT DESIGN

www.ewatersystems.com



TOP VIEW

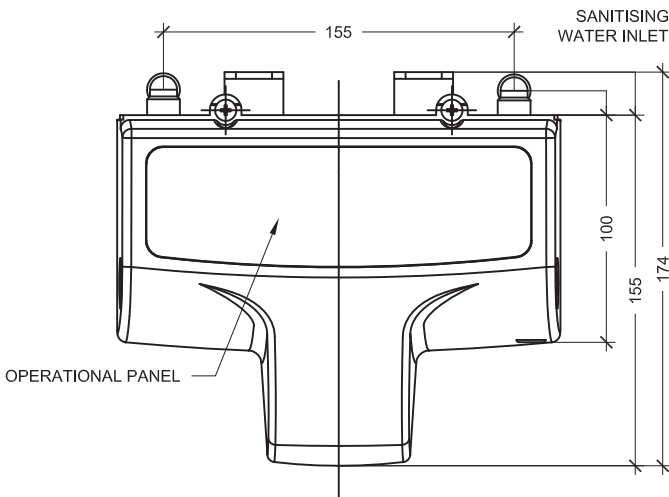

REAR VIEW

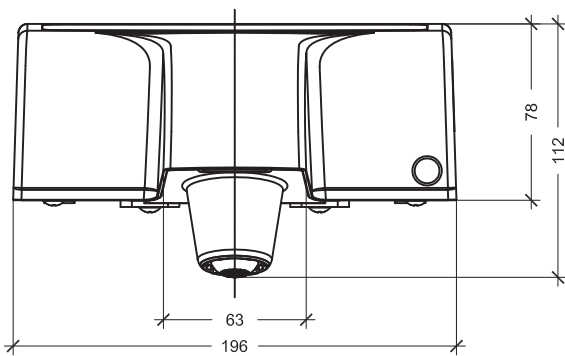
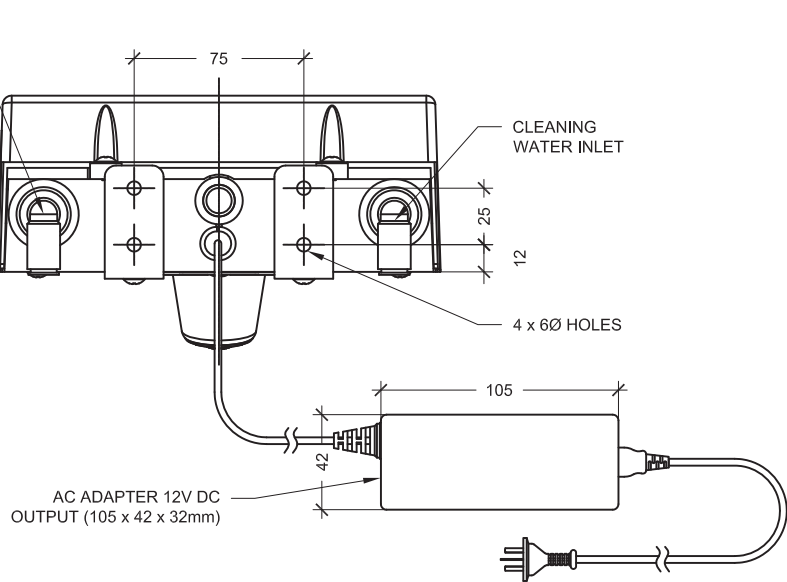

FRONT VIEW

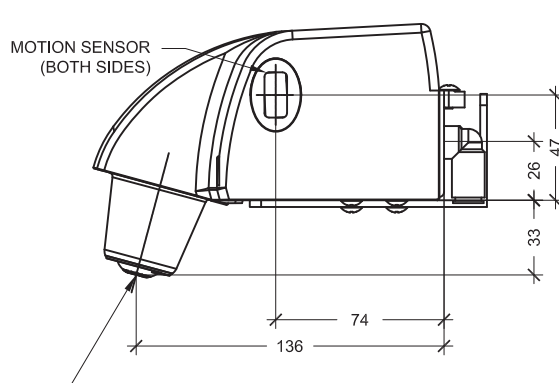

SIDE VIEW

VDW HAND WASH DISPENSER											
REF	DESCRIPTION	PLANT DETAILS				ELECTRICAL DETAILS			CONNECTION DETAILS		COMMENTS
		NO.	MANUFACTURER	MODEL	DIMENSIONS (mm)	LOAD	NECESSITY	BMS	CLEANING WATER INLET(mm)	SANITIZING WATER INLET (mm)	
eWS-HWD-1 TO 9	eWATER SYSTEMS VDW HAND WASH DISPENSER	9	HOSHIZAKI	VDW-2PB-E	196L x 174W x 112H	1 x 240V, 50 Hz, 10 Amp GPO's	NON ESSENTIAL	NO	1 x 12mm	1 x 12mm	<ul style="list-style-type: none"> - MAXIMUM RECOMMENDED PRESSURE 200kPa - HINGED TYPE ACCESS PANELS, NOT SCREW TYPE, OF SUFFICIENT DEPTH TO FIT ISOLATION VALVES, POWER GPO AND TRANSFORMER, ACCESS PANELS TO BE INSTALLED BY OTHERS. - COMPLETE WITH BACKING PLATE - WARM WATER REQUIRED AT BASINS IN ADDITION TO eWATER VDW HANDWASH DISPENSERS